

## ANALYSIS OF CAR PLATE HOLDER CONSTRUCTIONS

Mukhtorov Sherzodjon Sobirjon oglu

Fergana Polytechnic Institute

### ANNOTATION

This article provides recommendations on how to prevent the design and defects of the plate handles that attach to the windshield, which connects the rear-view mirror to the windshield.

**Keywords:** Window, 3M structural connecting tape, plate handle.

### INTRODUCTION

Mashinasozlik sanoati rivojlanib brogan sari ishlab chiqarilayotgan mashina va mexanizimlar, ularni sifati, ish unumdorligi, ishlash muddatlariga talab kundan kunga ortib bormoqda. Shu navbatda avtomobillarni old oynasiga maxkamlanuvchi orqani ko'rish uchun mo'jalangan ko'zguni old oyna bilan maxkam ushlab turuvchi plastina tutqichiga bo'lgan talab ortib borayotgani ko'rishimiz mumkin. Bunga sabab avtomobilda harakatlanish mobaynida orqada kelayotgan avtomobilni va orqaga harakatlanishni kuzatib borish uchun xizmat qiladi.



1-rasm. Hozirgi kundagi yetakchi avtomobil ishlab chiqaruvchi zavodlarini avtomobillari uchun ishlatiladigan old oynalar.

Mashinasozlikda avtomobillar ishlab chiqarish sanoati qanchali rivojlangan sari, avtomobillar old oynasiga maxkamlanuvchi plastina tutqichiga bo'lgan talab ham kuchayib boryapti. Sabab ko'zgularni zamonaviy korinishlari va konstruksiyalari rivojlanib kelmoqda. Shu o'rinda yangi turdagi plastina tutqichlari konstruksiyasiga bo'lgan talab ham o'sib bormoqda. Hozirgi kundagi avtomobillar uchun plastina tutqichilarni turlarini 2-rasmda ko'rsarilgan.



2-rasm. Zamonaviy avtomobillarni 20 xil turdagi plastina tutqichlarini ko'rishlari.

Umumiy ish sharoitida plastina tutqichi biriktirish pnevmatik moslamada 30-50 N/sm bosim bilan amalga oshiriladi. Odatda ushlab turish shartlari 140°C da 10 sekund. Bu oddiy avtoklav jarayonlariga javob beradi.

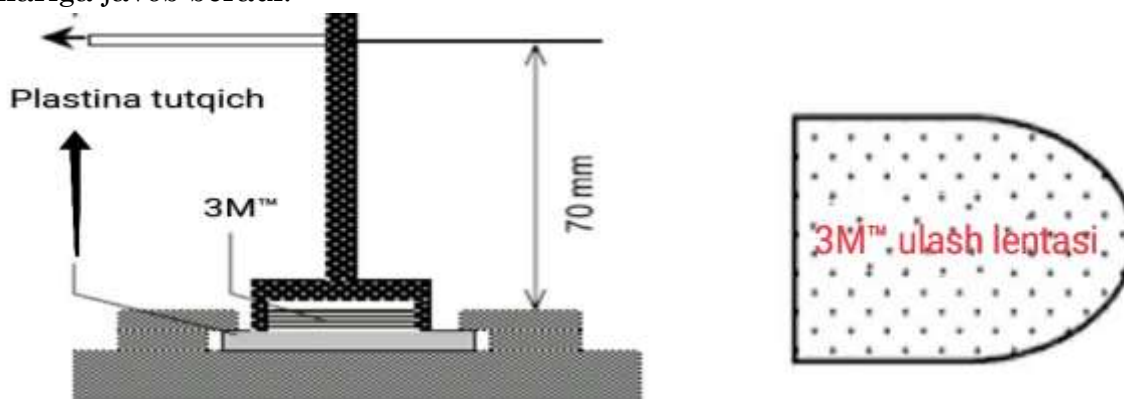

3-rasm. 3M strukturali ulash lentasini plastina tutqichiga yopishtirish sxemasi.

Ushbu jarayonda 3M strukturali ulash lentasini plastina tutqichiga yopishtirish jarayoni ko'rsatilgan. Bu texnologik jarayonda 3M strukturali ulash lentasini avtomatik liniyada pnevmatik moslama yordamida plastina tutqichlarga mos perimetrda kesib joylab boradi. Bu pnevmatik moslama universal bo'lib, har qanday turdagi plastina tutqichiga moslasa bo'ladi. Hozirgi kundagi avtomobil ishlab chiqaruvchi zavodlar o'z avtomobillari uchun 3M strukturali ulash lentasidan foydalanadi.

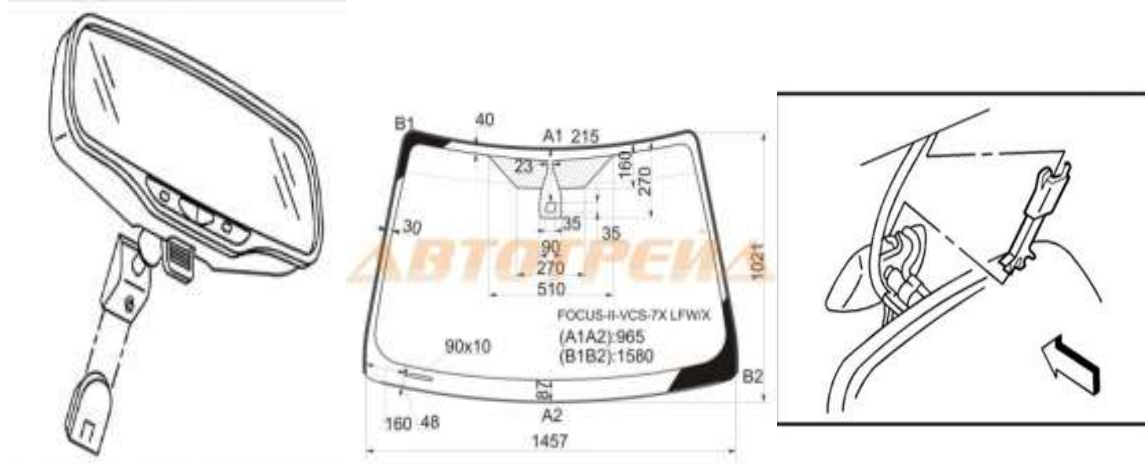

4-rasm. Avtomobil old oynasiga 3M strukturali ulash lentasi orqali plastina tutqichini maxkamlab ko'zguni o'rnatish sxemasi va parametri.

Old oynaga plastina tutqichini maxkamlangandan keyin ko'zguni plastina tutqichiga kirgizib maxkamlash sxemasi ko'rsatib o'tilgan. Ushbu yig'ish jarayonida parametrlarga asosan yig'ish lozim. Sabab ko'zgu old oyna yuqori qismida hamda markazida bo'lishi lozim.

3M strukturali ulash lentasini ikki xil turidan avtomobil ishlab chiqarishda foydalaniladi. 3M germetik va lentali turlaridan plastina tutqichi uchun lentalisidan foydalaniladi.



5-rasm. 3M strukturali ulash lentasini germetik va lentali turlari.

Ushbu ulash lentasi orqali barcha turdagi plastina tutqichlarni oynaga maxkamlash uchun foydalanish mumkin. Hozirgi kundagi zamonaviy avtomobillar ishlab chiqaruvchi zavod talablariga to'la javob beradi.

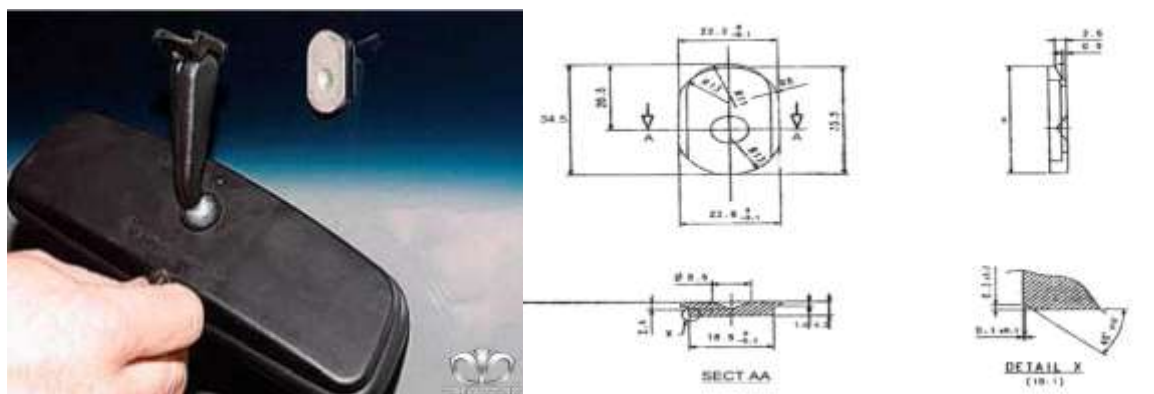

6-rasm. №9263 sonli avtomobil plastina tutqichi chizmasi.

Bu plastina tutqich №9263 sonli plastina tutqichi xisoblanadi. Ushbu plastina tutqich Uz.DAEWOO zavodida Tiko, Matiz, Nexia avtomabillari uchun ishlatilgan. Avzaligi pastga tepaga ko'zguvni harakatini cheklovchi chuqurcha mavjudligi. Kamchiligi yuk ko'tara olish qobiliyati pastligi. Sabab old oynaga yopishuvchi yuzasi kichikligi va yopishuvchi yuzasi aniqligi pastligidadir.

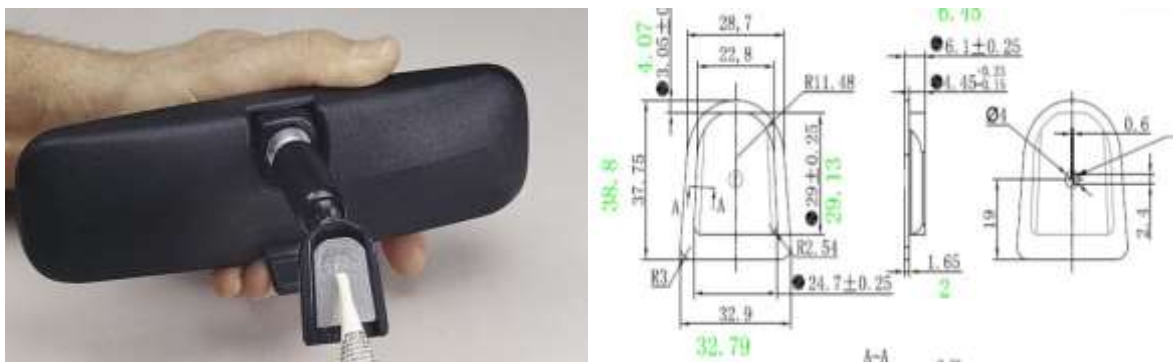

7-rasm. №9270 sonli avtomobil plastina tutqich chizmasi.

№9270 sonli avtomabillar plastina tutqichi xisoblanadi. Ushbu turdagi plastini tutqichlar GM zavodi avtomabillaridan Coblt, Nexia 3R larga ishlatiladi. Kamchligi avtomat karobka avtomabillar uchun ishlatilmaydi. Sabab ko'zguni original variantiga mos kelmaydi. Afzalligi old oynaga maxkamlangan( №9270) plastinaga kirish jarayonida oynada kirish chizig'i hosil qilmaydi.

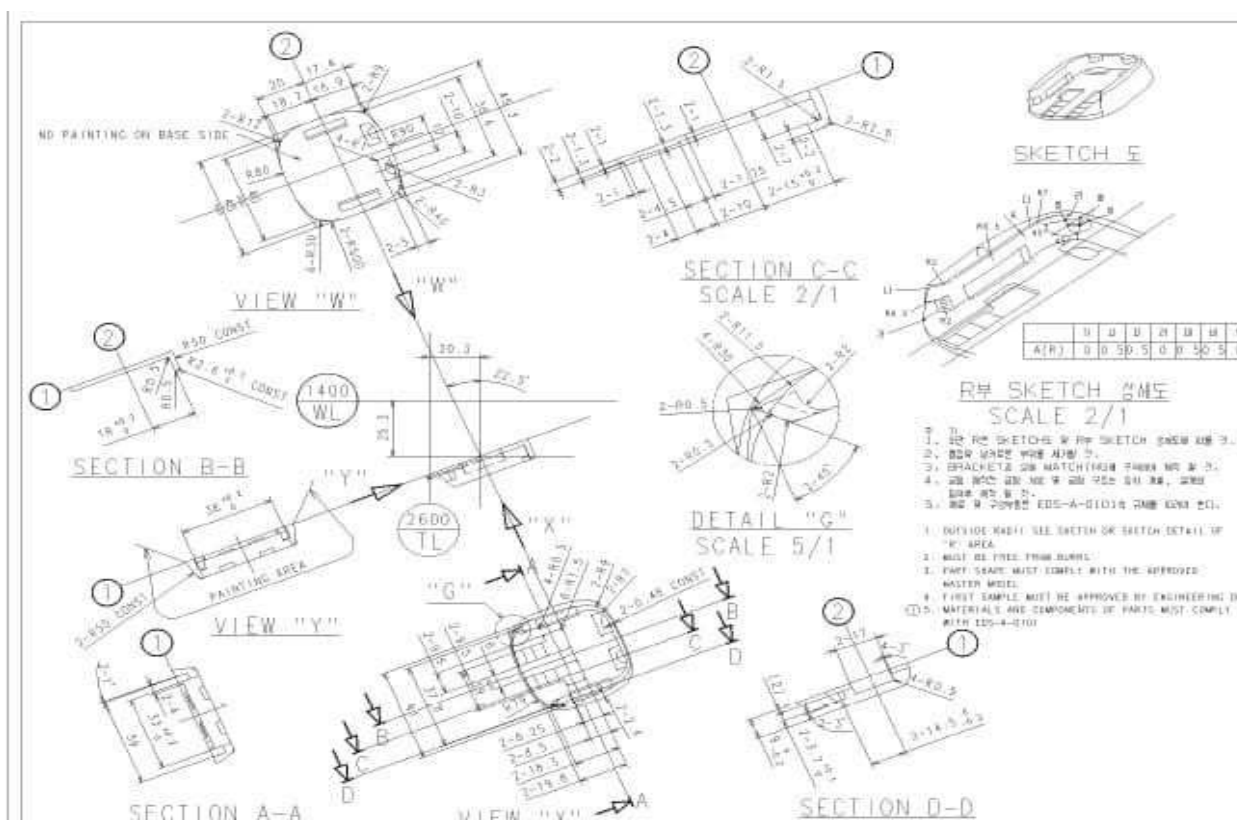

Bu turdagi plastina tutqichlar GM (O'zbekiston) Zavodida ishlab chiqaruvchi avtomabillardan Lacetti, Malibu avtomabillari uchun ishlatiladi. №193561 sonli plastina tutqichi bo'lib, tirovchi detallarni qisib qoluvchi ariqchasi mavjudligi foydali taraflaridan biri bo'lib xizmat qiladi.

## FOYDALANILGAN ADABIYOTLAR

1. Axmadbek Maxmudbek o'g'li Turg'unbekov, & Abdumajidxon Murodxon o'g'li Muxtorov (2021). Theoretical Studies Of The Technological Process Of Machining Parts With Concave Surfaces Of Complex Forms On Cnc Milling Machines. Journal of Innovations in Social Sciences 1(1) ,90-97.
2. Turg'unbekov Axmadbek Maxmudbek o'g'li (2021). THEORETICAL STUDIES OF THE TECHNOLOGICAL PROCESS OF MACHINING PARTS WITH CONCAVE SURFACES OF COMPLEX FORMS ON CNC MILLING MACHINES. 1(8), 122-128. <https://doi.org/10.5281/zenodo.5710406>
3. Alisher Axmadjon o'g'li Botirov, & Axmadbek Maxmudbek o'g'li Turg'unbekov. (2021). EXPERIMENTAL STUDIES OF THE TECHNOLOGICAL PROCESS OF PROCESSING CONCAVE SURFACES OF COMPLEX SHAPES. Eurasian Journal of Academic Research, 1(8), 222–231. <https://doi.org/10.5281/zenodo.5727625>
4. Botirov, Alisher Akhmadjon Ugli , & Turg'unbekov, Akhmadbek Makhmudbek Ugli (2021). INVESTIGATION OF PRODUCTIVITY AND ACCURACY OF PROCESSING IN THE MANUFACTURE OF SHAPING EQUIPMENT. Oriental renaissance: Innovative, educational, natural and social sciences, 1 (11), 435-449.
5. Abdullayeva, Donoxon Toshmatovna, & Turg'unbekov, Axmadbek Maxmudbek O'G'Li (2021). ПРОДЛЕНИЕ СРОКА ХРАНЕНИЯ ЛИСТОВЫХ ДЕТАЛЕЙ ПРОКАТНОГО ОБОРУДОВАНИЯ. Oriental renaissance: Innovative, educational, natural and social sciences, 1 (11), 1035-1045.
6. I. O. Ergashev, R. J. Karimov, A. M. Turg'unbekov, & S. S. Nurmatova (2021). ARRALI JIN MASHINASIDAGI KOLOSNIK PANJARASI BO'YICHA OLIV BORILGAN ILMIY TADQIQOTLAR TAHLILI. Scientific progress, 2 (7), 78-82.
7. Ахмадбек Махмудбек Ўғли Турғунбеков (2021). НОТЕХНОЛОГИК ЮЗАНИНГ ТЕШИКЛАРИГА ИШЛОВ БЕРИШДА ДОРНАЛАШ УСУЛИНИ ТАДБИҚ ЭТИШ. Scientific progress, 2 (1), 4-10.
8. Abdumajidxon Murodxon O'G'Li Muxtorov, & Axmadbek Maxmudbek O'G'Li Turg'unbekov (2021). VAKUUM XALQALARI UCHUN SILIKON MATERIALLARNI TURLARI VA ULARNING TAHLILI. Scientific progress, 2 (6), 1503-1508.
9. Kholmurzaev, A. A., & Tokhirov, I. K. (2021). The active participation of students in the formation of the educational process is a key to efficiency. ACADEMICIA: An International Multidisciplinary Research Journal, 11(4), 435-439.
10. Абдукаримов, Б. А., & Тохиров, И. Х. (2019). Research of convective heat transfer in solar air heaters. Наука, техника и образование, (9 (62)).
11. Арзиев, С. С., & Тохиров, И. Х. Ў. (2021). ФАЗОВИЙ ФИКРЛАШНИНГ БЎЛАЖАК МУҲАНДИС ВА АРХИТЕКТОРЛАР ИЖОДИЙ ФАОЛИЯТИДА ТУТГАН ЎРНИ. Scientific progress, 2(2), 438-442.
12. Холмурзаев, А. А., Тохиров, И. Х. У., & Охунжонов, З. Н. (2019). Движение летучки хлопка-сырца в зоне от вершины колка до отражающего козырька. Проблемы современной науки и образования, (11-2 (144)).

13. Усманов, Д. А., Каримов, Р. Х., & Полотов, К. К. (2019). Технологическая оценка работы четырехбарабанного очистителя. Проблемы современной науки и образования, (11-1 (144)).
14. Холмурзаев, А. А., Алижонов, О. И., Мадаминов, Ж. З., & Каримов, Р. Х. (2019). Эффективные средства создания обучающих программ по предмету «Начертательная геометрия». Проблемы современной науки и образования, (12-1 (145)).
15. Абдуллаева, Д. Т., Каримов, Р. Х., & Умарова, М. О. (2021). МАКТАБ ТАЪЛИМ ТИЗИМИДА ЧИЗМАЧИЛИК ФАНИНИ РИВОЖЛАНТИРИШ ВА БИЛИМ БЕРИШ ЖАРАЁНИНИ ТАКОМИЛЛАШТИРИШ. Scientific progress, 2(1), 323-327.
16. Валихонов, Д. А. Ў., Ботиров, А. А. Ў., Охунжонов, З. Н., & Каримов, Р. Х. (2021). ЭСКИ АСФАЛЬТО БЕТОННИ КАЙТА ИШЛАШ. Scientific progress, 2(1), 367-373.
17. Tobjiboyev R.K., Ulmasov A.A., & Muxtorov Sh. (2021). 3M structural bonding tape 9270. Science and Education, 2 (4), 146-149.S
18. Холмурзаев, А. А., & Охунжонов, З. Н. (2019). ДВИЖЕНИЕ ЛЕТУЧКИ ХЛОПКА-СЫРЦА В ЗОНЕ ОТ ВЕРШИНЫ КОЛКА ДО ОТРАЖАЮЩЕГО КОЗЫРЬКА. Проблемы современной науки и образования, (11-2), 19-21.
19. Muxtoraliyeva, R. M., Nosirjonovich, O. Z., & Zafarjonovich, M. J. (2020). Use of graphics computer software in the study of the subject" Drawing and engineering graphics". ACADEMICIA: An International Multidisciplinary Research Journal, 10(5), 83-86.
20. Валихонов, Д. А. Ў., Ботиров, А. А. Ў., Охунжонов, З. Н., & Каримов, Р. Х. (2021). ЭСКИ АСФАЛЬТО БЕТОННИ КАЙТА ИШЛАШ. Scientific progress, 2(1), 367-373.
21. Arziyev, S. (2021). ADVANTAGES OF USING THREE-DIMENSIONAL VISUAL VIEWS IN TEACHING THE SUBJECT «DESCRIPTIVE GEOMETRY». Збірник наукових праць SCIENTIA.
22. Arziyev, S. (2021). ADVANTAGES OF USING THREE-DIMENSIONAL VISUAL VIEWS IN TEACHING THE SUBJECT «DESCRIPTIVE GEOMETRY». Збірник наукових праць SCIENTIA.
23. Арзиев, С. С., & Тохиров, И. Х. Ў. (2021). ФАЗОВИЙ ФИКРЛАШНИНГ БЎЛАЖАК МУҲАНДИС ВА АРХИТЕКТОРЛАР ИЖОДИЙ ФАОЛИЯТИДА ТУТГАН ЎРНИ. Scientific progress, 2(2), 438-442.
24. Zulfiya, B., Rakhmonali, S., & Murodjon, K. (2021). A BRIEF HISTORY OF THE DEVELOPMENT AND TEACHING OF DRAWING SCIENCE IN UZBEKISTAN.
25. Karimov, R. (2021). PLANNING OF BELT BRIDGE FOR UNSYMMETRICAL PROGRESSIVE STAMPING. Scientific progress, 2(2), 616-623.
26. Karimov, R. J. O. G. L., & Toxtasinov, R. D. O. (2021). FEATURES OF CHIP FORMATION DURING PROCESSING OF POLYMER COMPOSITE MATERIALS. Scientific progress, 2(6), 1481-1487.
27. Karimov, R. J. O. G. L., O'G'Li, S. S. D., & Oxunjonov, Z. N. (2021). CUTTING HARD POLYMER COMPOSITE MATERIALS. Scientific progress, 2(6), 1488-1493.
28. Mamajonovich, X. A., Omonbekovna, U. M., & Toshmatovna, A. D. (2020). The rectification of curve flat arch. ACADEMICIA: An International Multidisciplinary Research Journal, 10(5), 62-65. h. (2021). 3M structural bonding tape 9270. Science and Education, 2 (4), 146-149.